

## KFC-225 AUTOPILOT - MAINTENANCE PRACTICES

### 1. General

- A. A three-axis autopilot with heading hold is installed as standard equipment on the airplane. The dual-axis system gives both vertical speed and altitude hold selection. Altitude alerting and altitude preselection are optional features with the two-axis autopilot system.

### 2. Roll Servo Removal/Installation

- A. Remove the Roll Servo (Refer to Figure 201).

- (1) Make sure the BATT and AVIONICS switches are in the off position.
- (2) Remove the copilot's seat. Refer to Chapter 25, Flight Compartment - Maintenance Practices.
- (3) Remove the access panel (232DR). Refer to Chapter 6, Access Plates and Plates Identification - Description and Operation.
- (4) Disconnect the electrical connector from the roll servo.
- (5) Release the control cable tension and loosen the roll servo control cable at the turnbuckle.
- (6) Remove the bolts and washers that attach the roll servo to the bracket assembly.
- (7) Remove the roll servo from the airplane.

- B. Install the Roll Servo (Refer to Figure 201).

- (1) Put the roll servo in position on the bracket assembly and attach with the bolts and washers.
- (2) Connect the electrical connector to the roll servo.
- (3) Install the roll servo control cable on the roll servo.
- (4) Make sure the aileron and bell crank are in the neutral position.
- (5) Wind the control cable around the servo drum approximately 1.25 turns in each direction from the swaged ball (drum ball detent inboard).
- (6) Make sure the flanges of the control cable guard do not touch the control cable.
- (7) Make sure the flanges of the control cable guard are on each side of the notches around the outer edge of the mount.
- (8) Adjust the roll servo control cable tension to 12 pounds, +2 or -2 pounds.
- (9) Tighten bolts on cable clamps to 50 inch pounds, + 5 or - 5 inch pounds (5.64 N-m, +0.564 or - 0.564 N-m).
- (10) Install the access panel. Refer to Chapter 6, Access Plates and Plates Identification - Description and Operation.
- (11) Install the copilot's seat. Refer to Chapter 25, Flight Compartment - Maintenance Practices.
- (12) Put the BATT and AVIONICS switches in the ON position.
- (13) Do a operational test of the autopilot. Refer to Introduction in the List of Manufacturers Technical Publications for the manufacturer's installation manual.

### 3. Pitch Servo Removal/Installation

- A. Remove Pitch Servo (Refer to Figure 202).

- (1) Make sure the BATT and AVIONICS switches are in the off position.
- (2) Remove the Rear Compartment Wall. Refer to Chapter 25, Rear Compartment Wall - Maintenance Practices.
- (3) Disconnect the electrical connector from the pitch servo.
- (4) Release the control cable tension and loosen the pitch servo control cable at the turnbuckle.
- (5) Remove the bolts and washers that attach the pitch servo to the bracket assembly.
- (6) Remove the pitch servo from the airplane.

- B. Install the Pitch Servo (Refer to Figure 202).

- (1) Put the pitch servo in position on the bracket assembly and attach with the bolts and washers.
- (2) Connect the electrical connector to the pitch servo.
- (3) Install the pitch servo control cable on the pitch servo actuator.
- (4) Make sure the elevator and bell crank are in the neutral position.
- (5) Wind the control cable around the servo drum approximately 1.25 turns in each direction from the swaged ball (drum

ball detent inboard).

- (6) Make sure the flanges of the control cable guard do not touch the control cable.
- (7) Make sure the flanges of the control cable guard are on each side of the notches around the outer edge of the mount.
- (8) Make sure that the main cables tension is set correctly.
- (9) Use the turnbuckle to adjust the pitch servo cable tension to 20 pounds, +5 or -5 pounds.
- (10) Install the Rear Compartment Wall. Refer to Chapter 25, Rear Compartment Wall - Maintenance Practices.
- (11) Put the BATT and AVIONICS switches in the ON position.
- (12) Do a operational test of the autopilot. Refer to Introduction in the List of Manufacturers Technical Publications for the manufacturer's installation manual.

#### 4. Yaw Servo Removal/Installation

##### A. Remove Yaw Servo (Refer to Figure 203).

- (1) Make sure the BATT and AVIONICS switches are in the off position.
- (2) Remove the Rear Compartment Wall. Refer to Chapter 25, Rear Compartment Wall - Maintenance Practices.
- (3) Disconnect the electrical connector from the yaw servo.
- (4) Release the control cable tension and loosen the yaw servo control cable at the turnbuckle.
- (5) Remove the bolts and washers that attach the yaw servo to the bracket assembly.
- (6) Remove the yaw servo from the airplane.

##### B. Install the Yaw Servo (Refer to Figure 203).

- (1) Put the yaw servo in position on the bracket assembly and attach with the bolts and washers.
- (2) Connect the electrical connector to the yaw servo.
- (3) Install the yaw servo control cable on the yaw servo actuator.
- (4) Make sure the rudder and bell crank are in the neutral position.
- (5) Wind the control cable around the servo drum approximately 1.25 turns in each direction from the swaged ball (drum ball detent inboard).
- (6) Make sure the flanges of the control cable guard do not touch the control cable.
- (7) Make sure the flanges of the control cable guard are on each side of the notches around the outer edge of the mount.
- (8) Make sure that the main cables tension is set correctly.
- (9) Use the turnbuckle to adjust the yaw servo cable tension to 20 pounds, +5 or -5 pounds.
- (10) Install the Rear Compartment Wall. Refer to Chapter 25, Rear Compartment Wall - Maintenance Practices.
- (11) Put the BATT and AVIONICS switches in the ON position.
- (12) Do a operational test of the autopilot. Refer to Introduction in the List of Manufacturers Technical Publications for the manufacturer's installation manual.

#### 5. Pitch Trim Servo Removal/Installation

##### A. Remove the Pitch Trim Servo (Refer to Figure 204).

- (1) Make sure the BATT and AVIONICS switches are in the off position.
- (2) Get access to the pitch trim servo. Refer to Chapter 27, Electric Elevator Trim - Removal/Installation.  
**NOTE: The Electric Elevator Trim - Removal/Installation section gives the method necessary to remove and install the electric elevator trim motor that is installed on some models. This same method is valid to remove and install the pitch trim servo.**
- (3) Disconnect the electrical connector from the pitch trim servo.
- (4) Remove the pitch trim servo from the airplane.

##### B. Install the Pitch Trim Servo (Refer to Figure 204).

- (1) Install the pitch trim servo in the airplane. Refer to Chapter 27, Electric Elevator Trim - Removal/Installation.  
**NOTE: The Electric Elevator Trim - Removal/Installation section gives the method necessary to remove and install the electric elevator trim motor that is installed on some models. This same method is valid to remove and install the pitch trim servo.**

- (2) Connect the electrical connector to the pitch trim servo.
- (3) Close access to the pitch trim servo. Refer to Chapter 27, Electric Elevator Trim - Removal/Installation.
- (4) Put the BATT and AVIONICS switches in the ON position.
- (5) Do an operational test of the autopilot. Refer to Introduction of the List of Manufacturers Technical Publications, for the manufacturer's installation manual.

## 6. Roll Servo Inspection

- A. Do an Inspection of the Roll Servo (Refer to Figure 201).
  - (1) Remove the servo cover.

**CAUTION: Make sure the maintenance personnel and the table are electrically grounded. Do disassembly or assembly of the servo at an electrostatic-safe area.**

    - (a) Put an electrical ground on the maintenance personnel and table.
    - (b) Remove the two screws that attach the cover to the unit.
    - (c) Carefully remove the cover over the wiring harness.
    - (d) Put the servo on the table so the inner parts of the unit will not be damaged.
  - (2) Do inspection of the solenoid and clutch.
    - (a) Make sure the solenoid shaft moves freely in and out of the solenoid body.
    - (b) Make sure there is no dirt, contamination or corrosion around the solenoid shaft.
    - (c) Make sure the release spring freely pulls the shaft out of the solenoid and against the stop fitting.
    - (d) Make sure the pinion gear turns and does not touch the clutch gears.
  - (3) Do a general inspection of the roll servo.
    - (a) Examine the electrical wiring for indication of wear or damage of the insulation.
    - (b) Examine the servo for any loose hardware or other defects.
  - (4) Install the cover.
    - (a) Carefully put the cover in position.
    - (b) Install the screws with Loctite 222 or Loctite 242.
  - (5) Remove the servo capstan assembly and do a check of the slip-clutch torque setting (Refer to Servo Capstan Clutch Adjustment).

## 7. Pitch Servo Inspection

- A. Do an Inspection of the Pitch Servo (Refer to Figure 202).
  - (1) Remove the servo cover.

**CAUTION: Make sure the maintenance personnel and the table are electrically grounded. Do disassembly or assembly of the servo at an electrostatic-safe area.**

    - (a) Put an electrical ground on the maintenance personnel and table.
    - (b) Remove the two screws that attach the cover to the unit.
    - (c) Carefully remove the cover from the wiring harness.

**CAUTION: Do not move any wires, tie wraps or the spring clamp. The position of each is set by the manufacturer and is necessary for correct operation.**
    - (d) Put the servo on the table so the inner parts of the unit will not be damaged.
  - (2) Do inspection of the solenoid and clutch.
    - (a) Make sure the solenoid shaft moves freely in and out of the solenoid body.
    - (b) Make sure there is no dirt, contamination or corrosion around the solenoid shaft.
    - (c) Make sure the release spring freely pulls the shaft out of the solenoid and against the stop fitting.
    - (d) Make sure the pinion gear turns and does not touch the clutch gears.
  - (3) Do a general inspection.
    - (a) Examine the electrical wiring for indication of wear or damage of the insulation.

- (b) Examine the servo for any loose hardware or other defects.
- (4) Do an inspection of the pitch servo motor.
  - (a) Put the servo in position so the baseplate is on the bottom side of the unit.
  - (b) Hold the top section of the motor and carefully turn the motor shaft.
  - (c) The motor shaft must turn freely from side to side a small quantity.
- (5) Install the cover.
  - (a) Carefully put the cover in position.
  - (b) Install the screws with Loctite 222 or Loctite 242.
- (6) Remove the servo capstan assembly and do a check of the slip-clutch torque setting (Refer to Servo Capstan Clutch Adjustment).

## 8. YAW Servo Inspection

- A. Do an Inspection of the Pitch Trim Servo (Refer to Figure 203).

- (1) Remove the servo cover.

**CAUTION: Make sure the maintenance personnel and the table are electrically grounded. Do disassembly or assembly of the servo at an electrostatic-safe area.**

- (a) Put an electrical ground on the maintenance personnel and table.
- (b) Remove the two screws that attach the cover to the unit.
- (c) Carefully remove the cover over the wiring harness.
- (d) Put the servo on the table so the inner parts of the unit will not be damaged.
- (2) Do inspection of the solenoid and clutch.
  - (a) Make sure the solenoid shaft moves freely in and out of the solenoid body.
  - (b) Make sure there is no dirt, contamination or corrosion around the solenoid shaft.
  - (c) Make sure the release spring freely pulls the shaft out of the solenoid and against the stop fitting.
  - (d) Make sure the pinion gear turns and does not touch the clutch gears.
- (3) Do a general inspection.
  - (a) Examine the electrical wiring for indication of wear or damage of the insulation.
  - (b) Examine the servo for any loose hardware or other defects.
- (4) Install the cover.
  - (a) Carefully put the cover in position.
  - (b) Install the screws with Loctite 222 or Loctite 242.
- (5) Remove the servo capstan assembly and check the slip-clutch torque setting (Refer to Servo Capstan Clutch Adjustment).

## 9. Pitch Trim Servo Inspection

- A. Do an Inspection of the Pitch Trim Servo (Refer to Figure 204).

- (1) Remove the servo cover.

**CAUTION: Make sure the maintenance personnel and the table are electrically grounded. Do disassembly or assembly of the servo at an electrostatic-safe area.**

- (a) Put an electrical ground on the maintenance personnel and table.
- (b) Remove the two screws that attach the cover to the unit.
- (c) Carefully remove the cover over the wiring harness.
- (d) Put the servo on the table so the inner parts of the unit will not be damaged.
- (2) Do inspection of the solenoid and clutch.
  - (a) Make sure the solenoid shaft moves freely in and out of the solenoid body.
  - (b) Make sure there is no dirt, contamination or corrosion around the solenoid shaft.
  - (c) Make sure the release spring freely pulls the shaft out of the solenoid and against the stop fitting.

- (d) Make sure the pinion gear turns and does not touch the clutch gears.
- (3) Do a general inspection.
  - (a) Examine the electrical wiring for indication of wear or damage of the insulation.
  - (b) Examine the servo for any loose hardware or other defects.
- (4) Install the cover.
  - (a) Carefully put the cover in position.
  - (b) Install the screws with Loctite 222 or Loctite 242.
- (5) Remove the servo capstan assembly and check the slip-clutch torque setting (Refer to Servo Capstan Clutch Adjustment).

## 10. Pitch Trim Rigging Inspection

- A. Do a check of the pitch trim rigging.
  - (1) Attach an inclinometer to the trim tab.
  - (2) Put the trim tab in the 0 degree position.
  - (3) Manually operate the trim tab to the up and down limits.
  - (4) Record the limits of travel.
  - (5) Put an observer at the right-hand access opening of the tailcone.
  - (6) Put the electrical trim to the full nose-up position until the observer sees the clutch slip.
  - (7) Turn the manual trim wheel nose-up (test load condition) 1/4 turn more while the clutch slips.
  - (8) Make sure the swaged ball on the control cable assembly does not turn aft of the tangent point.
  - (9) Release the trim wheel and disengage the autopilot.
  - (10) Manually operate the trim to the full nose-up position.
  - (11) Do a check of the trim tab position with an inclinometer.
  - (12) Trim tab position that is greater than the limits of travel values recorded is an indication that the stop blocks slipped.
    - (a) Do the trim system rigging again.
    - (b) Make sure the stop block bolts torque is correct.
    - (c) Repeat the check of the pitch trim rigging.
  - (13) If necessary, make adjustments to the swaged ball position.
    - (a) Put the control cable assembly chain in the applicable position on the gear teeth of the actuator sprocket.  
**NOTE: One chain link adjustment is related to approximately 17 degrees of travel on the capstan.**
    - (b) Apply the applicable tension to the control cable and repeat the check of the pitch trim rigging.
  - (14) Do the procedure again for the full nose-down trim condition.

## 11. Servo Capstan Clutch Adjustment

- A. Do a check of the clutch torque setting. Refer to Chapter 27, Aileron and Spoiler System - Adjustment/Test, Servo Slip Clutch Torque Setting to determine the servo mount part number and setting required for each axis of the airplane.
  - (1) Remove the servo capstan.
  - (2) Remove the control cable guard from the servo capstan.
  - (3) Attach the servo capstan on the capstan test stand. Refer to Aileron and Spoiler System - Adjustment/Test, Servo Slip Clutch Torque Setting.
  - (4) Place the adapter tool over the servo capstan.
  - (5) Insert the adapter pin from the straight up position to attach the adapter tool.
  - (6) Insert the torque wrench.
  - (7) Apply 28 VDC (1 amp maximum) electrical power to the test stand.
  - (8) Do a check of the torque reading with the test stand motor in the clockwise operation.  
**NOTE: The check of the torque reading will be done three times.**
    - (a) Put the capstan switch in the clockwise position.

- (b) Record the torque reading of the torque wrench.
- (c) Put the switch in the off position.
- (9) Do a check of the torque reading with the test stand motor in the counterclockwise operation.
  - NOTE: The check of the torque reading will be done three times.**
  - (a) Put the capstan switch in the counterclockwise position.
  - (b) Record the torque reading of the torque wrench.
  - (c) Put the switch in the off position.
- (10) Average the six torque readings.
  - NOTE: The torque reading to be used is the average of the six torque readings.**
- (11) Refer to Table 201 for the correct torque reading of the servo capstan.

**Table 201. KAP-150 and KFC 225 Autopilot Servo Clutch Torque Setting**

	208	208B
Roll Servo Capstan	33, +3 or -3 inch-pounds (3.7, +0.33 or -0.33 N-m)	38, +4 or -4 inch-pounds (4.3, 0.45 or -0.45 N-m)
Pitch Servo Capstan	43, +4 or -4 inch-pounds (4.9, +0.45 or -0.45 N-m)	43, +4 or -4 inch-pounds (4.9, +0.45 or -0.45 N-m)
Pitch Trim Servo Capstan	45, +5 or -5 inch-pounds (5.1, +0.56 or -0.56 N-m)	45, +5 or -5 inch-pounds (5.1, +0.56 or -0.56 N-m)
Yaw Servo Capstan	50, +5 or -5 inch-pounds (5.6, +0.56 or -0.56 N-m)	50, +5 or -5 inch-pounds (5.6, +0.56 or -0.56 N-m)

- (a) If the torque indication is below the value given in Table 201, rotate the clutch adjust nut clockwise and do the check of the torque readings again.
- (b) If the torque indication is above the value given in Table 201, rotate the clutch adjust nut counterclockwise and do the check of the torque readings again.
- (12) Record the slip clutch torque indication, airplane type, axis, and date on the decal attached to the servo mount body.
- (13) Install the control cable guard on the servo capstan.
- (14) Install the servo capstan.

## 12. Set the Autopilot Roll Null

- A. Set the Autopilot Roll Null (If the Autopilot is Installed).
  - (1) Make sure the autopilot flight computer completes the preflight test.
  - (2) Disconnect the roll servo connector from the airplane harness.
  - (3) Apply a ground to pin K of the harness connector.
  - (4) Connect a digital multimeter across the harness connector at pins D and L to monitor the servo drive voltage.
  - (5) Push the autopilot AP button on the autopilot flight computer to engage it.
    - (a) Make sure the default ROL mode is set.
      - NOTE: For example, the HDG, NAV or APR modes are not engaged.**
    - (b) Use a DMM to measure the DC voltage across pins D and L of the roll servo harness connector.
    - (c) Adjust the pot until a value of 0 volts, +0.020 or -0.020 volts are measured.
      - 1 If the end of the pot movement is reached before the servo drive is nulled, disengage the autopilot, turn the pot fully to the opposite stop and then engage the autopilot.
    - (d) The roll null adjustment range emulates a four turn pot that lets the method of the pot adjustment range to be set.
      - NOTE: This adjustment lets offsets be in the roll axes. This includes the turn coordinator.**
    - (e) Continue to turn the pot to null the voltage.
  - (6) Connect the airplane roll servo harness connector to the servo connector.

Tools, Equipment and Materials

**NOTE:** Equivalent alternatives can be used for the items that follow.

<b>NAME</b>	<b>NUMBER</b>	<b>MANUFACTURER</b>	<b>USE</b>
Test Stand	071-06028-0000	Honeywell International, Inc. 1 Technology Center Olathe, KS 66061	To hold the servo mount in position while the servo clutch torque setting is adjusted.
Adapter Tool	071-06021-0003	Honeywell International, Inc.	To adjust the servo clutch torque setting.
Adapter Pin	071-06021-0002	Honeywell International, Inc.	To adjust the servo clutch torque setting.

Figure 201 : Sheet 1 : Autopilot Roll Servo Installation

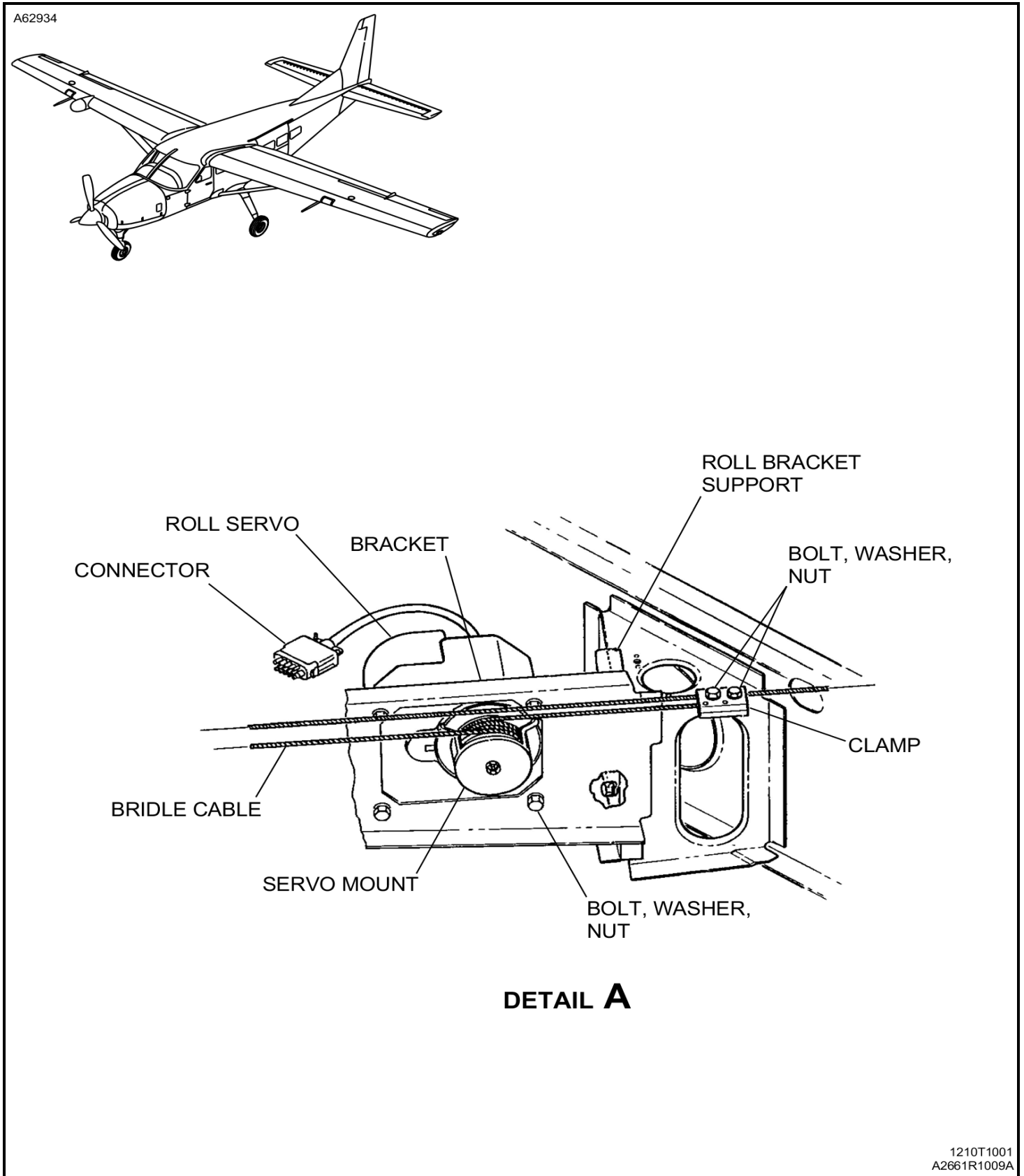



Figure 202 : Sheet 1 : Autopilot Pitch Servo Installation

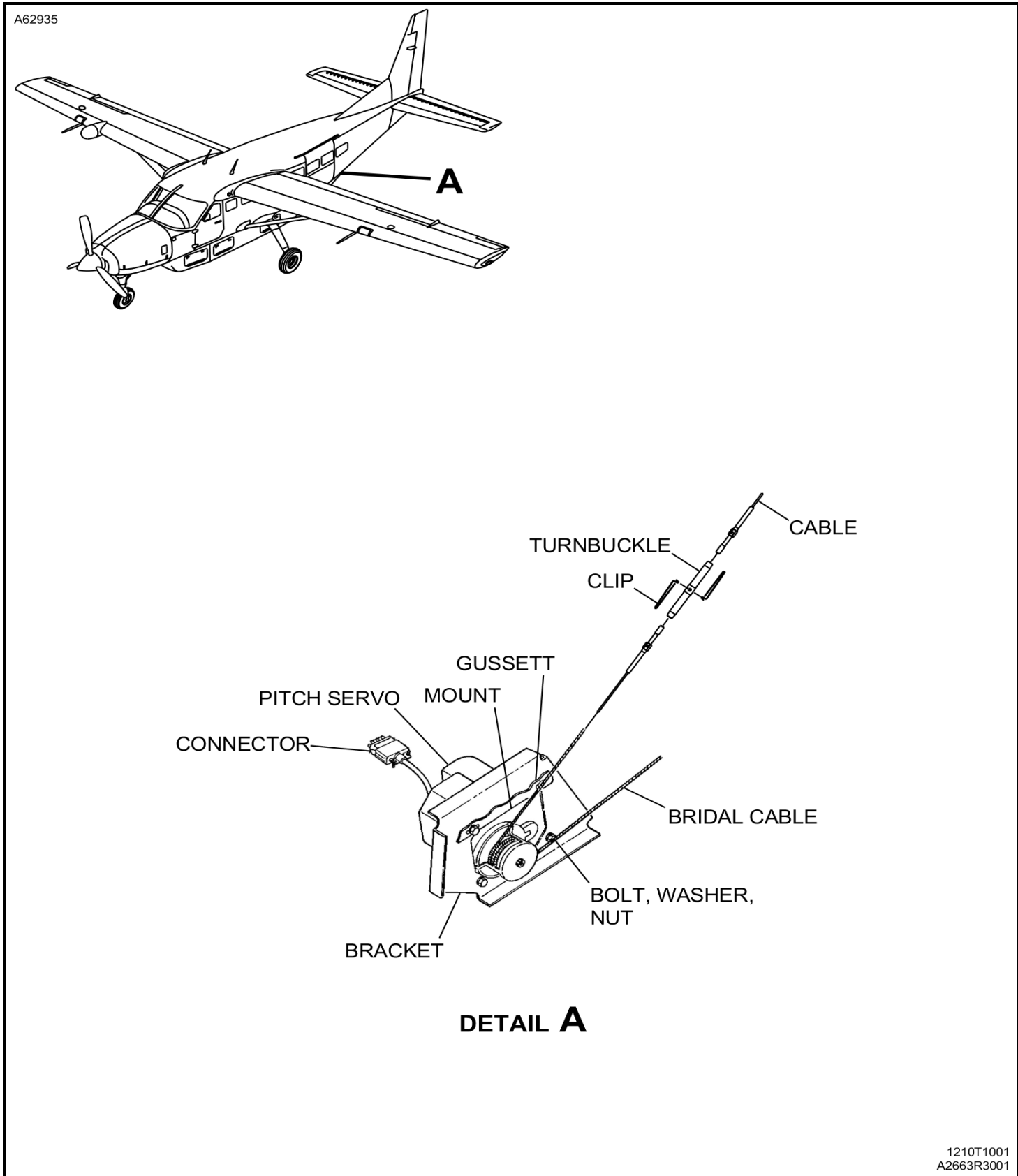

Figure 203 : Sheet 1 : Autopilot Yaw Servo Installation

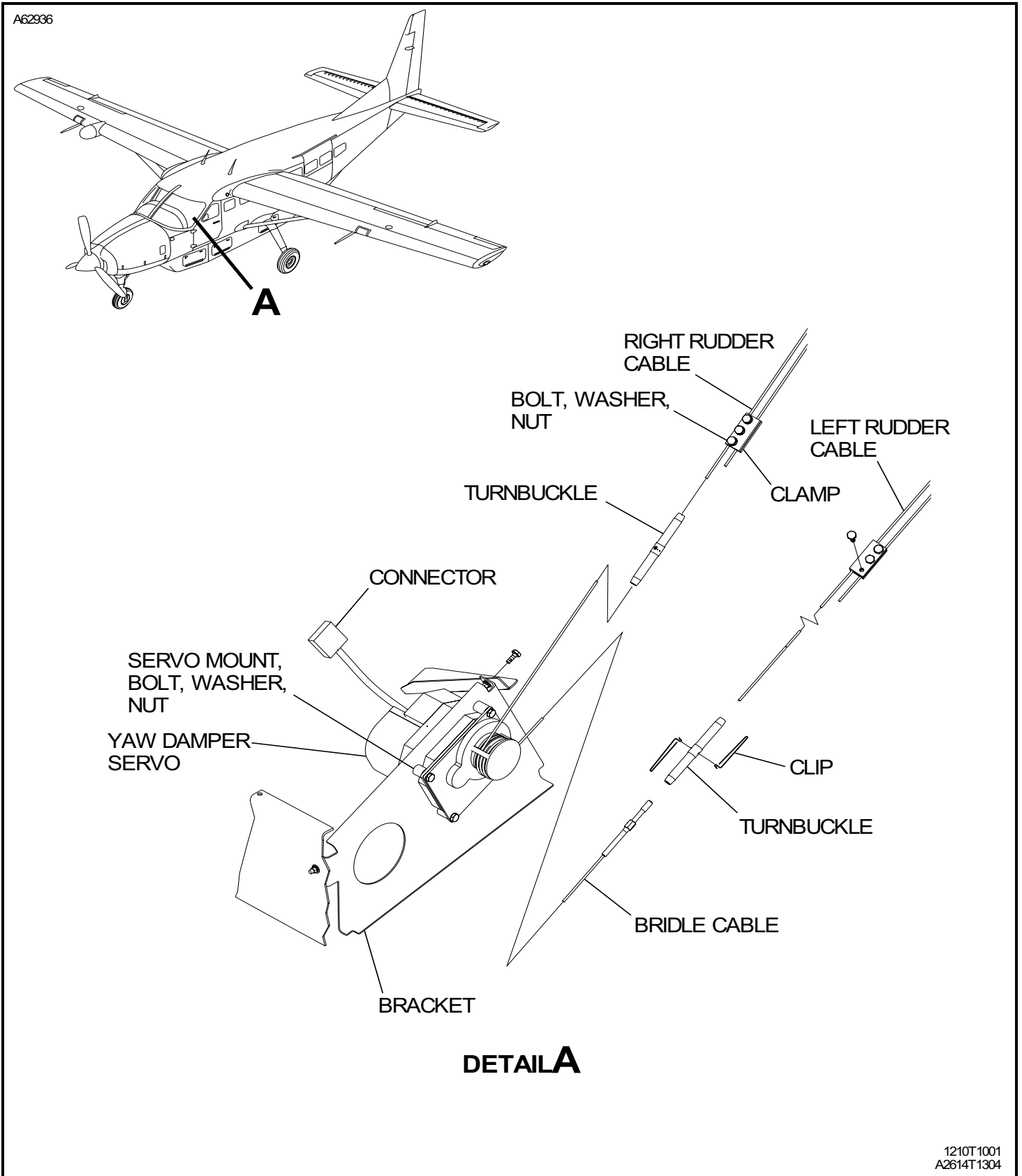
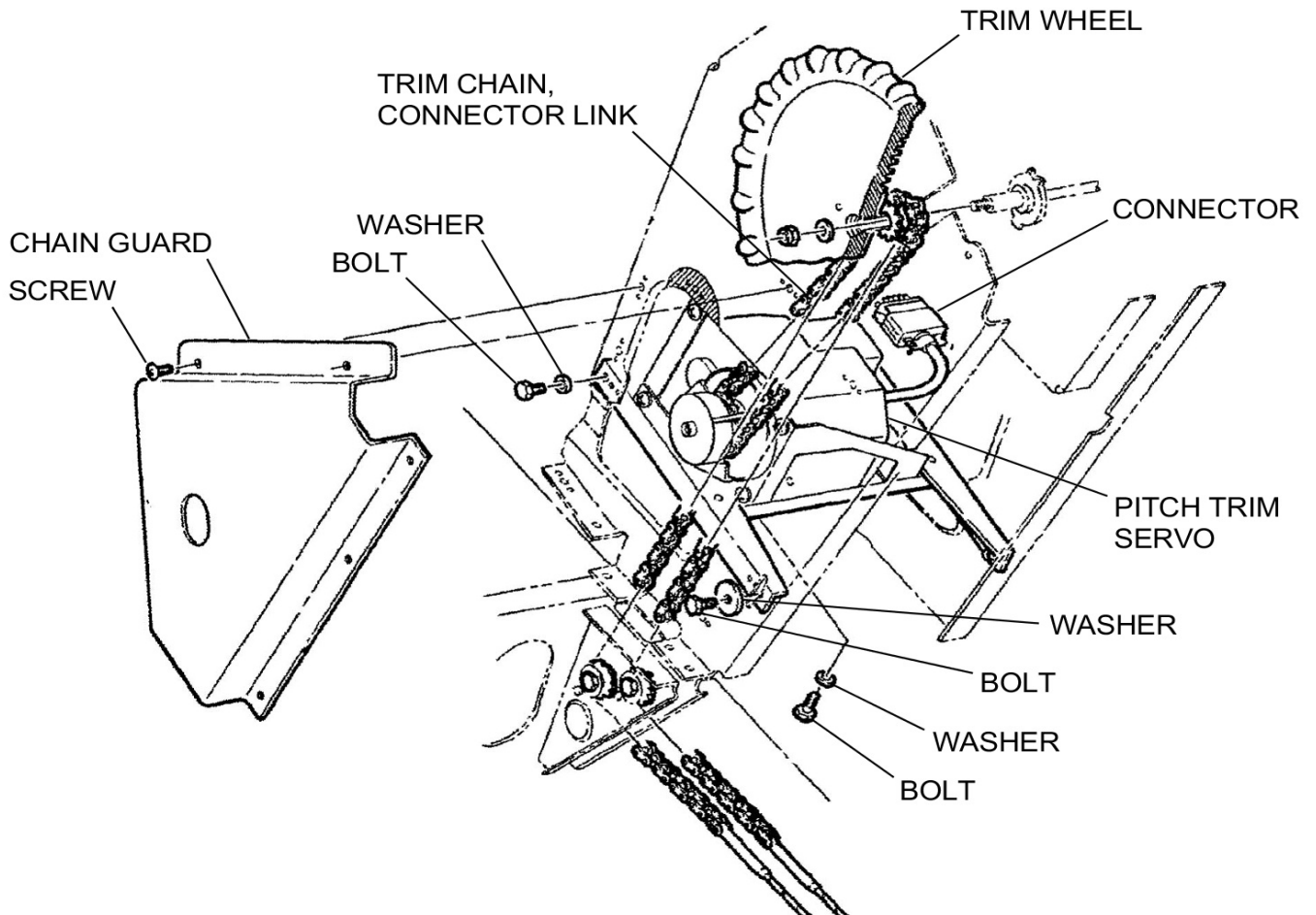
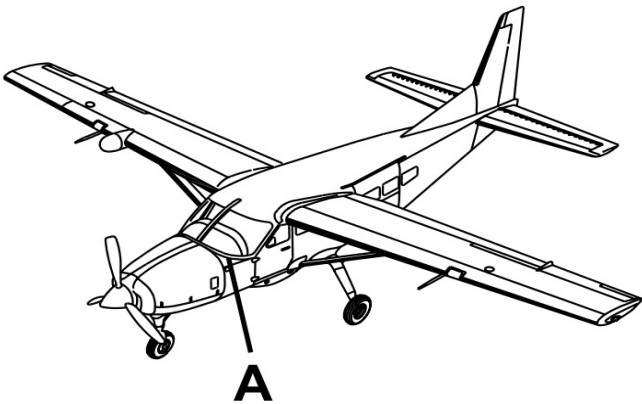

Figure 204 : Sheet 1 : Autopilot Pitch Trim Servo Installation

A62937



DETAIL A

2610T1032  
A2663R3002A